

Phone: 218-739-4641
Fax: 218-739-4008
www.shoremaster.com

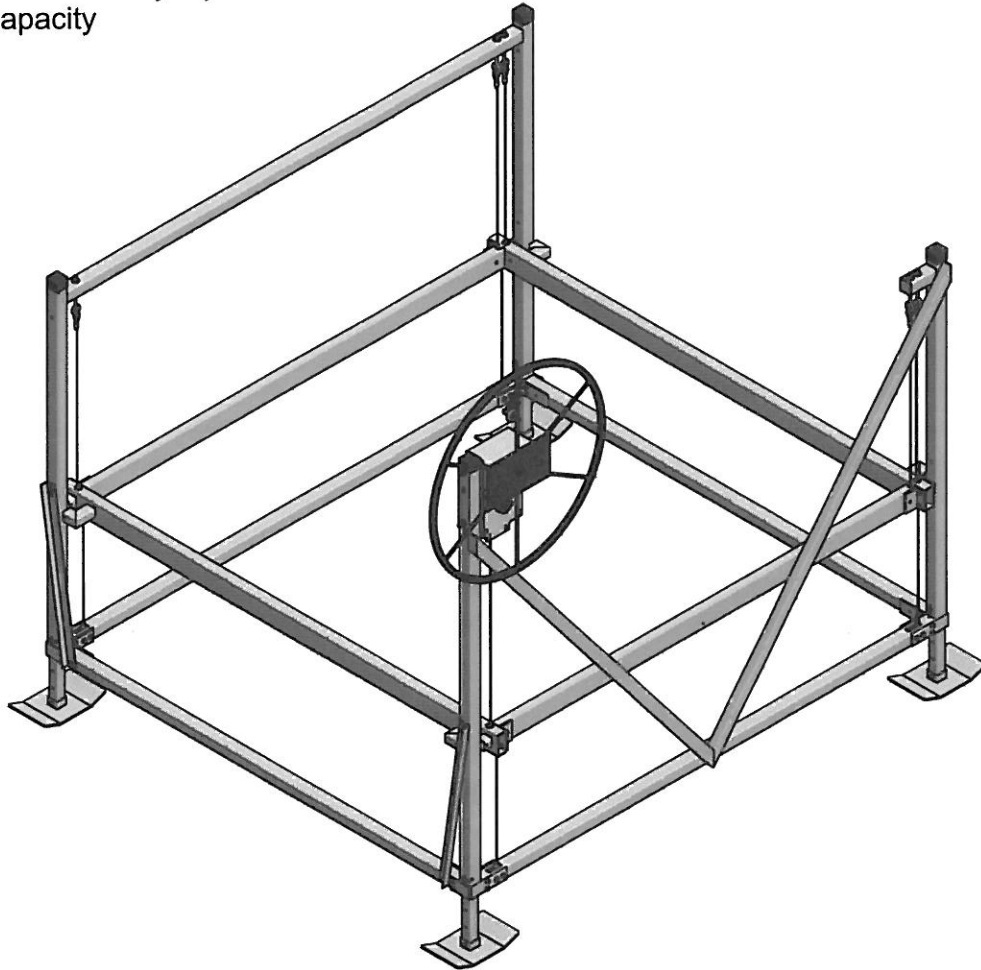

20855 Vertical Lift:

Instructions and Safety Tips
2000 lb. Capacity



CAUTION - PUT SAFETY FIRST

1. Before attempting to install or operate this hoist, study and fully understand the proper operating procedures and safety precautions outlined in this owner's manual.
2. Never exceed the recommended weight capacity of your lift. The lifted weight will include hull, engine, fuel, battery, and added accessories or gear. Weigh your fully loaded boat at a certified scale to be absolutely sure of the total weight.
3. Do not allow anyone on, in or under the lift while operating.
4. NOT COMPLYING WITH THE PROCEDURES AND PRECAUTIONS OUTLINED IN THIS MANUAL WILL INVALIDATE THE WARRANTY AND MAY RESULT IN PERSONAL INJURY OR DEATH.
5. If you have any questions about assembly, installation, operation or suitability of this product, contact an authorized dealer or ShoreMaster directly at 1-800-328-8945.

TABLE OF CONTENTS

Exploded Views	3-4
Accessories	5
Parts	6
Fasteners and Hardware	7-8
Assembly	9-15
Cable Locations	16
Winch / Wheel Assembly	17-19
Proper Cable Adjustment	20
Installation	21
Operation and Maintenance	22-23
Limited Warranty	24
Warranty Card	25

20855 VERTICAL LIFT

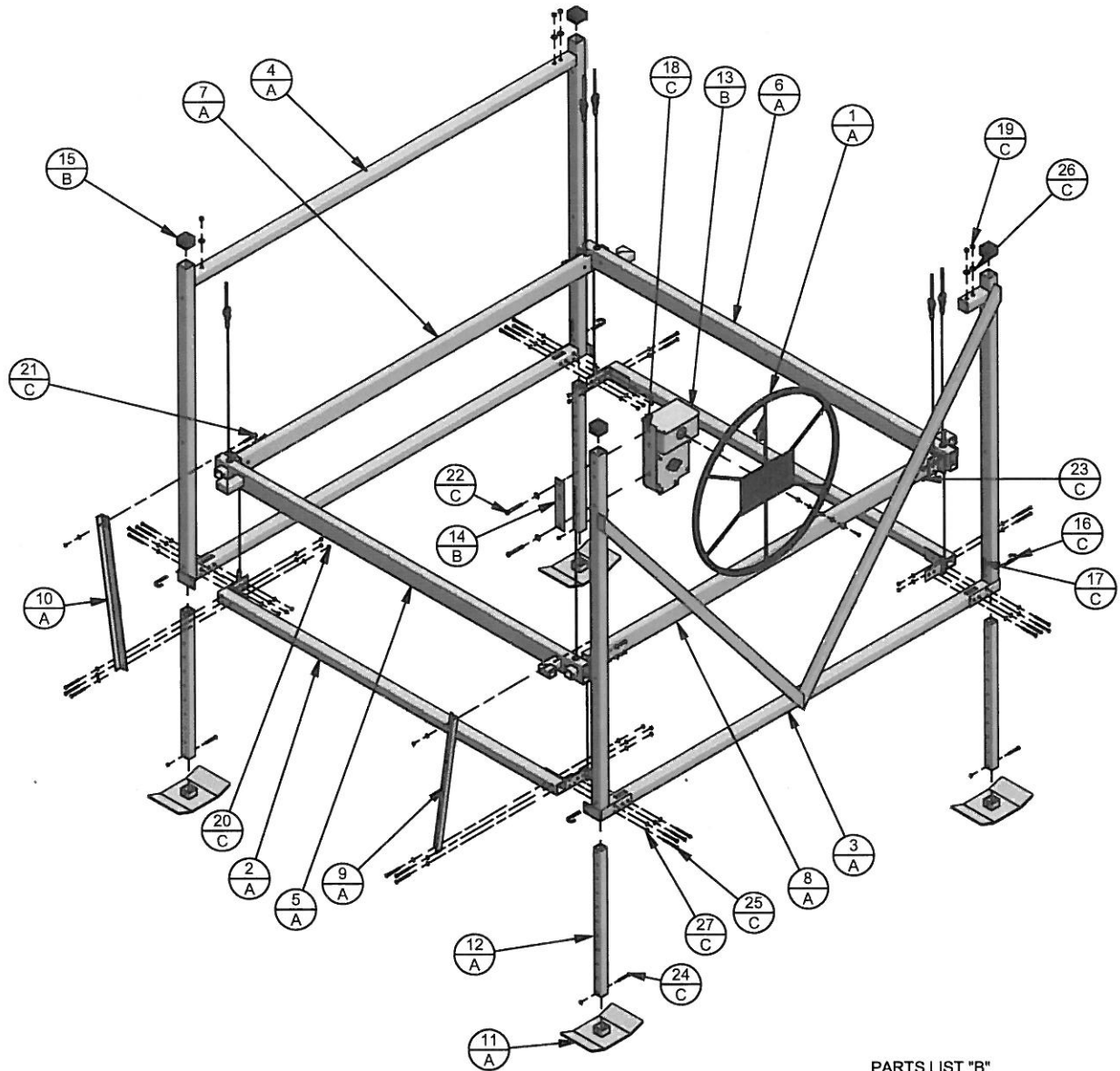

PARTS LIST "A"

310006160 - BUNDLE 20855 VERTICAL LIFT

ITEM	QTY	PART NUMBER	DESCRIPTION
1	1	LP00WHEEL	WHEEL
2	2	LP20855BB	BOTTOM BEAM
3	1	LP20855VS	LIFT V SIDE
4	1	LP20855S	LIFT OPPOSITE SIDE
5	1	110006250	FRONT RACK
6	1	110006170	REAR RACK
7	1	LP2085RRS	RIGHT RACK SIDE
8	1	LP2085LRS	LEFT RACK SIDE
9	1	LP2085BRC	LIFT BRACE LEFT
10	1	LP2085BRC	LIFT BRACE RIGHT
11	4	LP2000PAD	FOOT PAD
12	4	20603600D	LEG POST

PARTS LIST "B"

LWB020855 - WINCH/HARDWARE BOX 20855 VERTICAL

ITEM	QTY	PART NUMBER	DESCRIPTION
13	1	LP3000VWM	WINCH 3000
14	1	74401200H	WINCH PLATE
15	4	BLUECAP18	BLUE CAP

PARTS LIST "C"

LBB020855 - BOLT BAG COMPLETE 20855 VERTICAL

ITEM	QTY	PART NUMBER	DESCRIPTION
16	4	38LLPRGLG	PIN 3/8 X 2 17/32
17	4	LSPINCLIP	HAIR PIN
18	2	B120RGNUT	NUT 1/2 BRASS
19	5	B12 LOCNUT	NUT 1/2 NYLOC BRASS
20	40	B380RGNUT	NUT 3/8 BRASS
21	2	CS380412B	BOLT CARRIAGE 3/8 X 3.5
22	2	MM120400B	BOLT 1/2 X 4
23	8	MS380114B	BOLT 3/8 X 1.25
24	4	MS380234B	BOLT 3/8 X 2.75
25	26	MS380334B	BOLT 3/8 X 3.75
26	9	S120WASHR	WASHER FLAT 1/2
27	70	S380WASHR	WASHER FLAT 3/8

LIFT ACCESSORIES

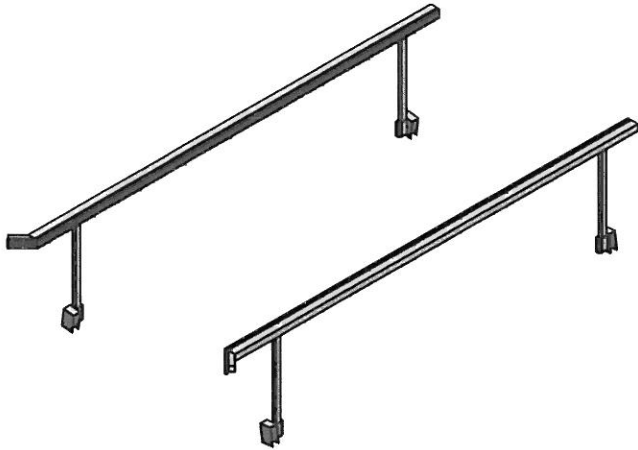

FULL LENGTH GUIDE
ALUM/ CARPETED WOOD
P/N - LAFULLGDE



UNIVERSAL LIFT
WHEEL CADDY
P/N - LAUNICADD

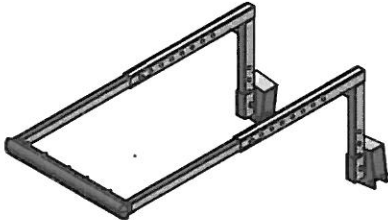

MOTOR STOP
P/N - LAADJSTOP

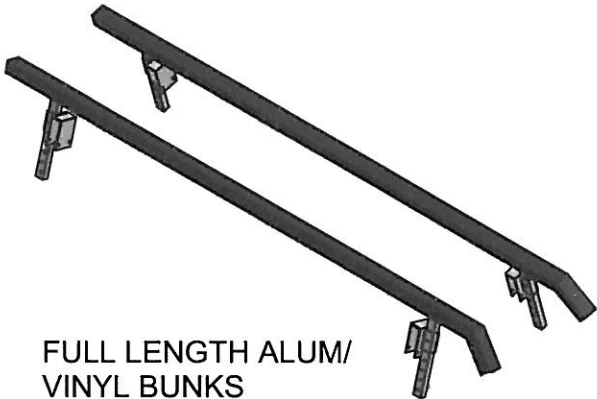

FULL LENGTH ALUM/
VINYL BUNKS
11' P/N - LAFULLBNK
14' P/N - LAFUL50BK

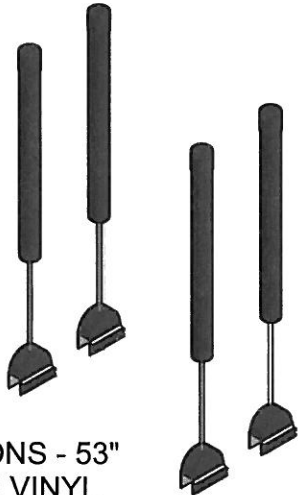

GUIDE PINS - 53"
W/ BLUE VINYL
P/N - LAGDEON53

PARTS LIST

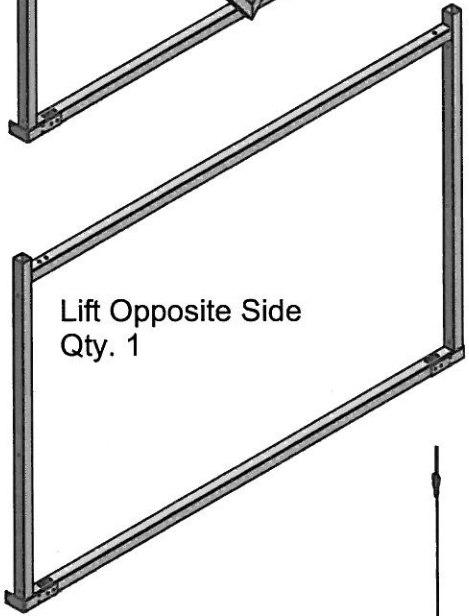
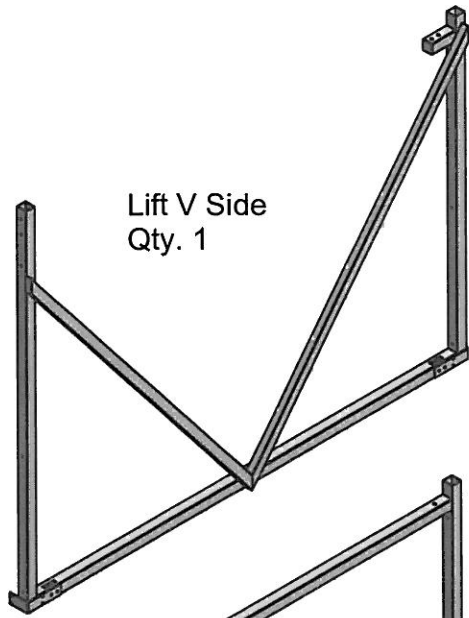

Right Rack Side
Qty. 1

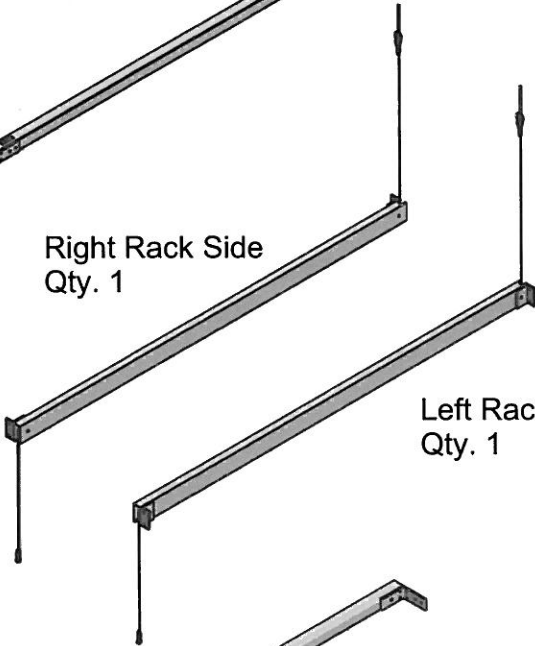

Bottom Beam
Qty. 2

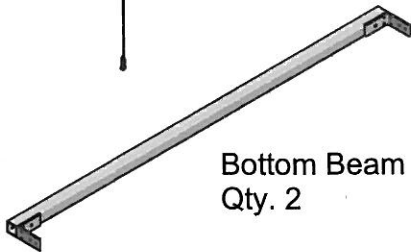

Foot Pad
Qty. 4

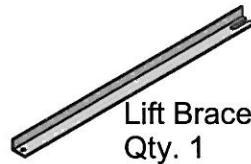

Lift Brace Right
Qty. 1

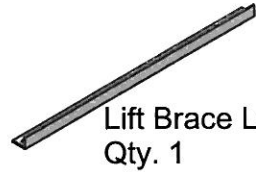

Lift Brace Left
Qty. 1



Winch Plate
Qty. 1

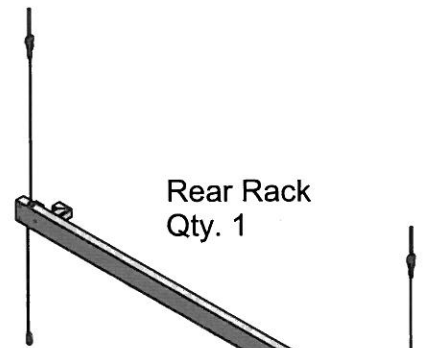

Rear Rack
Qty. 1

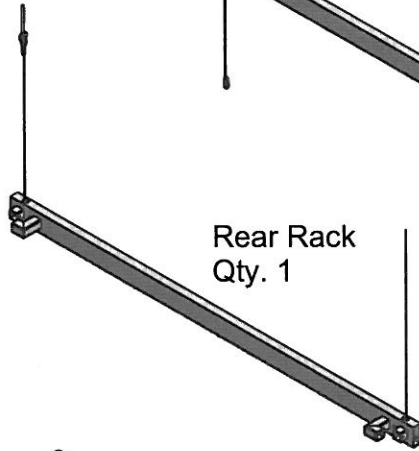

Rear Rack
Qty. 1

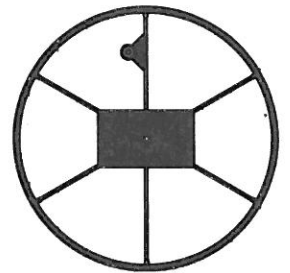

Wheel
Qty. 1

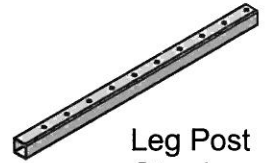

Leg Post
Qty. 4

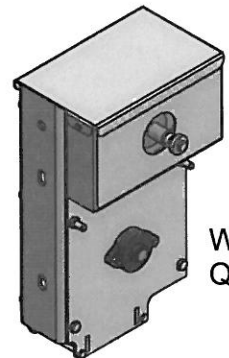

Winch
Qty. 1

FASTENERS AND HARDWARE

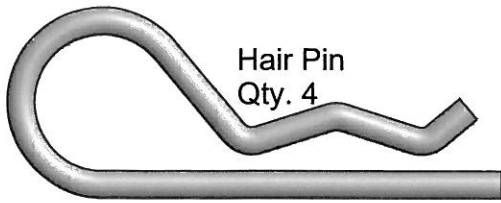

Hair Pin
Qty. 4

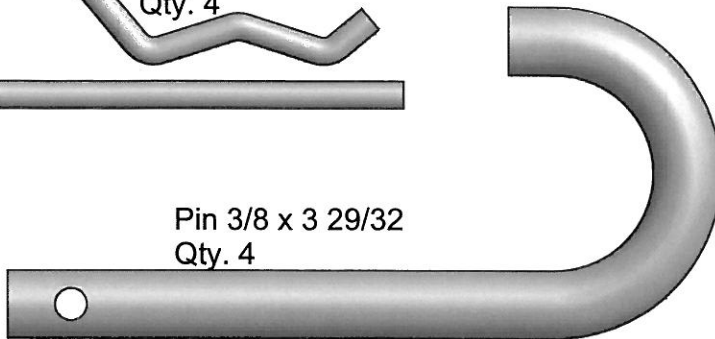

Pin 3/8 x 3 29/32
Qty. 4

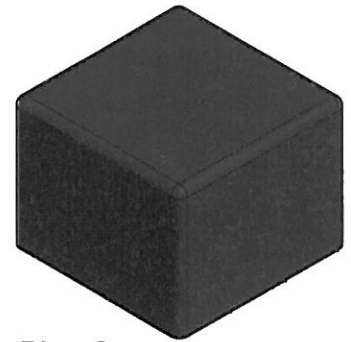

Blue Cap
Qty. 4

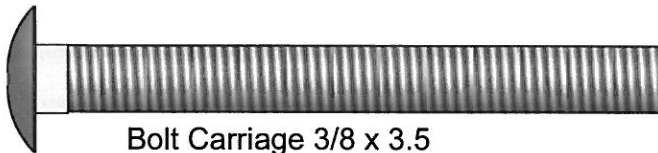

Bolt Carriage 3/8 x 3.5
Qty. 2

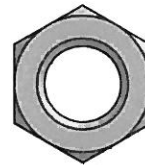

Nut 1/2 Brass
Qty. 2

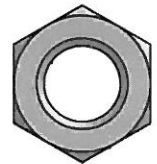

Nut 1/2 Nyloc Brass
Qty. 5



Bolt 3/8 x 1.25
Qty. 8



Nut 3/8 Brass
Qty. 40

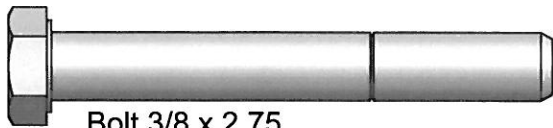

Bolt 3/8 x 2.75
Qty. 4

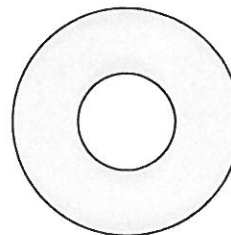

Washer Flat 1/2
Qty. 9



Bolt 3/8 x 3.75
Qty. 26

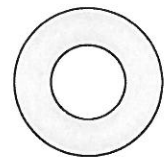

Washer Flat 3/8
Qty. 70

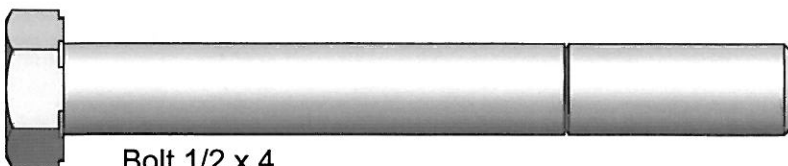

Bolt 1/2 x 4
Qty. 2

WINCH HARDWARE AND FASTENERS

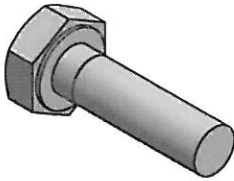

Bolt 5/16 x 1 Nyloc
Qty. 1



Washer Flat
Aluminum 1 1/8
Qty. 1



Washer Flat 5/16
Qty. 3



Spacer
Qty. 1



Bolt 1/4 x 4
Qty. 2



Nut 1/4 Nyloc
Qty. 2



Bolt 3/8 x 4.5
Qty. 2



Nut Jam 3/8 Nyloc Brass
Qty. 2

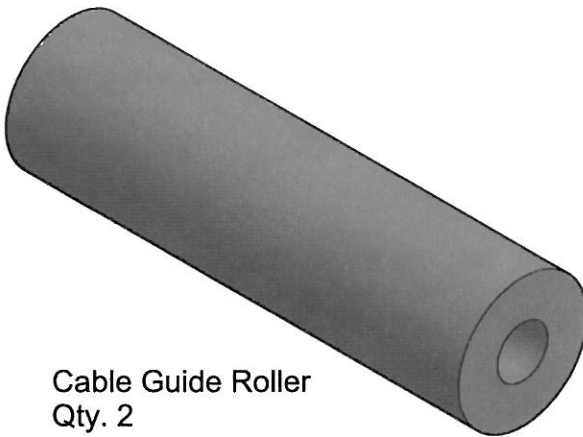

Cable Guide Roller
Qty. 2

ASSEMBLY INSTRUCTIONS

Your safety is the most important issue related to this product.

- Fully read and understand each step before proceeding with that step.
- Wear protective gloves, clothing and eyewear when assembling and installing the lift.
- Do not assemble, install or use this product if items are missing or damaged.

For ease of assembly find a flat area with plenty of room to assemble lift. The following tools will be needed for assembling lift:

1. Pair of 7/16" Wrenches
2. Pair of 9/16" Wrenches
3. Pair of 3/4" Wrenches
4. Measuring Tape
5. Hammer
6. 3/16" Allen Wrench

Only hand tighten bolts and nuts until lift is completely assembled. (see Step 8)

STEP 1

Slide Blue Caps on uprights as shown. Insert all four Leg Posts into Foot Pads, secure using one Bolt 3/8 x 2.75 and one Nut 3/8 Brass in each place. Insert Leg Posts into Lift V Side and Lift Opposite Side as shown. Use one Pin 3/8 x 2 17/32 and one Hair Pin for each Leg Post. No washers are used at this time.

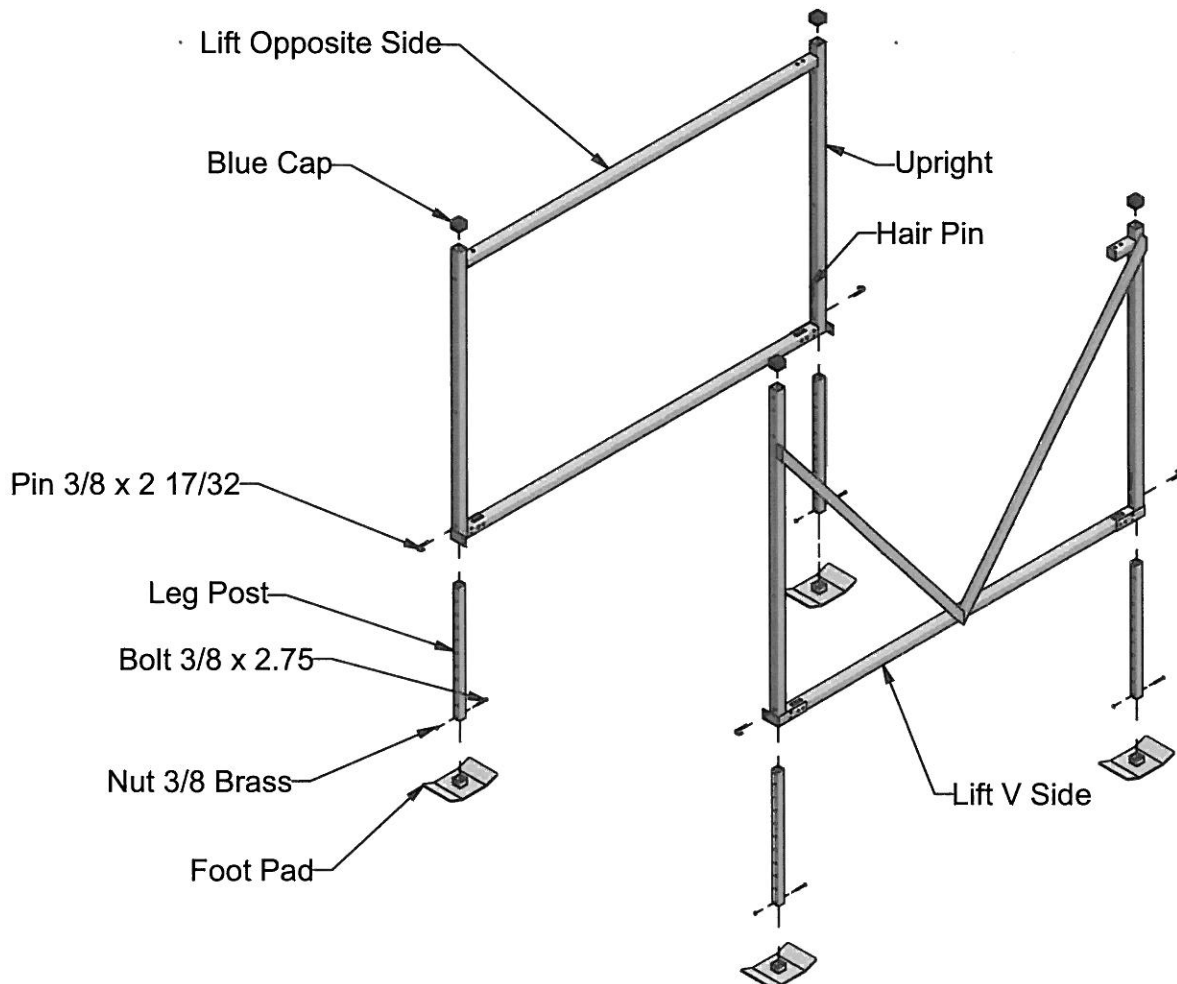

STEP 2

Place Lift V Side and Lift Opposite Side about eight feet apart as shown. Attach one Bottom Beam to *front* of Lift Sides as shown. Attach with one Bolt 3/8 x 3.75, two Washers Flat 3/8 and one Nut 3/8 Brass five places at each corner - as shown.

Note: The *front* is indicated by the winch mount attachment - as shown.

Note: Bolt only five of the six holes at each corner at this time. The remaining hole will be used in a later step. See Detail "A" for the one connection hole (in each front corner) not used at this time.

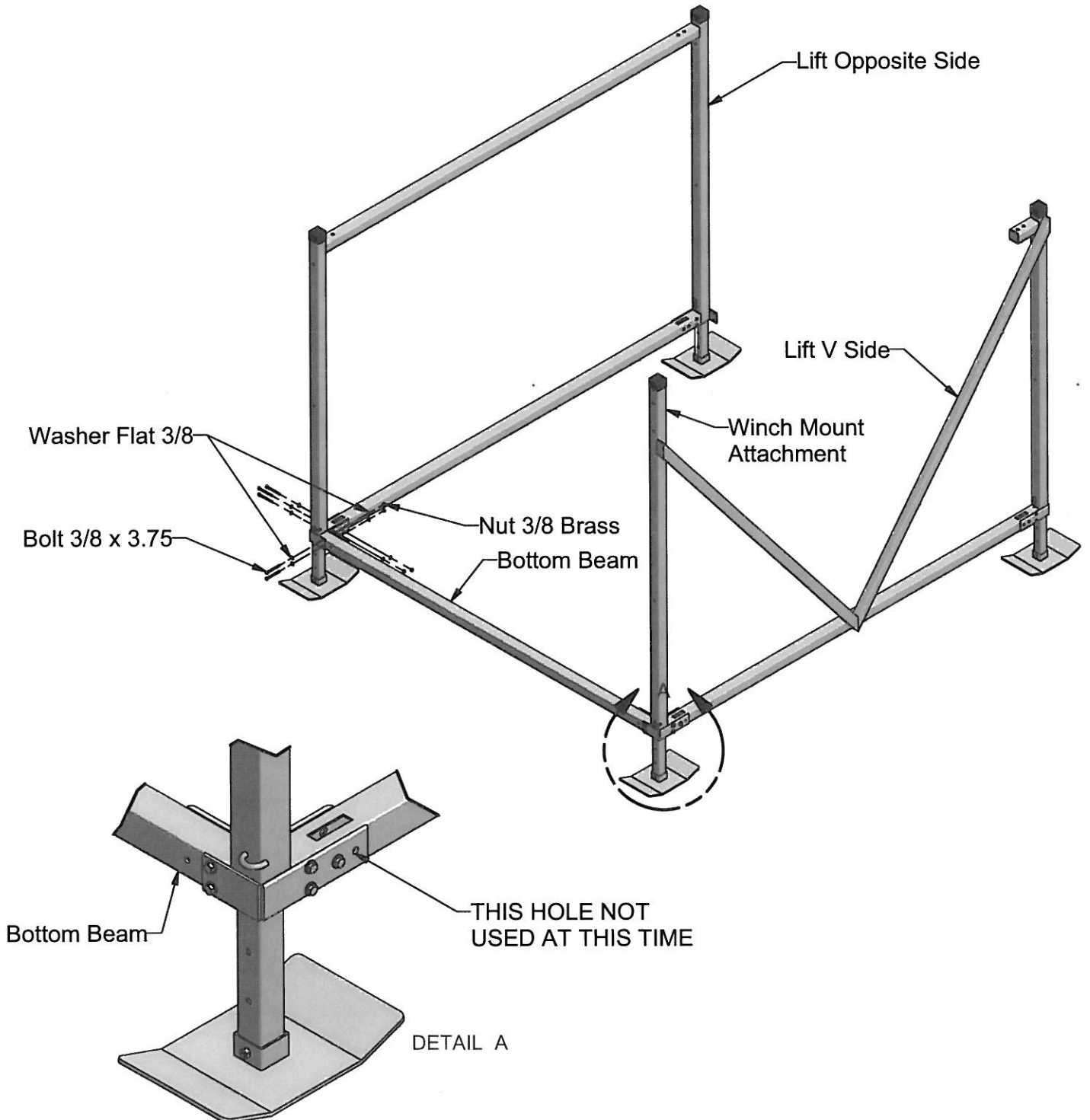

STEP 3

Attach one Lift Brace Left and one Lift Brace Right to the *front* of the Lift Sides and Bottom Beam as shown. Attach the ends of the Lift Braces to the Bottom Beam with one Bolt 3/8 x 3.75, two Washers Flat 3/8 and one Nut 3/8 Brass in 2 places. Attach the Slot end of the Lift Braces to the Lift Sides using one Bolt Carriage 3/8 x 3.25, one Washer Flat 3/8 and one Nut 3/8 Brass in 2 places.

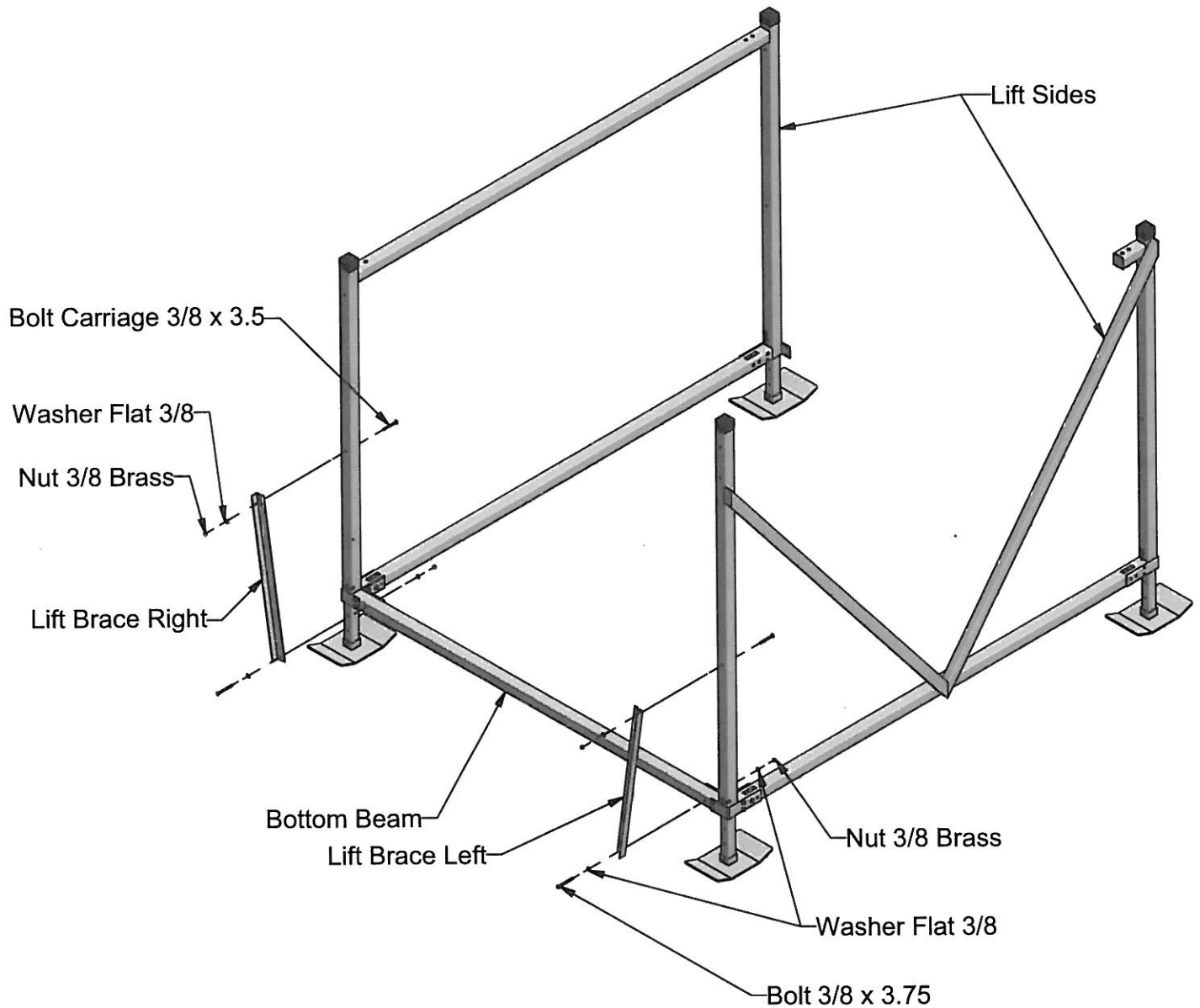

Note: Take two measurements between the two Lift Sides, one at the top and one at the bottom. The measurement should be the same at the top and bottom of the Lift Sides.

STEP 4

Attach the Bottom Beam to rear of Lift Sides as shown. Secure with one Bolt 3/8 x 3.75, two Washers Flat 3/8 and one Nut 3/8 Brass in five places at each corner - as shown.

Note: Bolt only five of the six holes at each corner at this time. The remaining hole will be used in a later step. See Detail "A" for the one connection hole (in each rear corner) not used at this time.

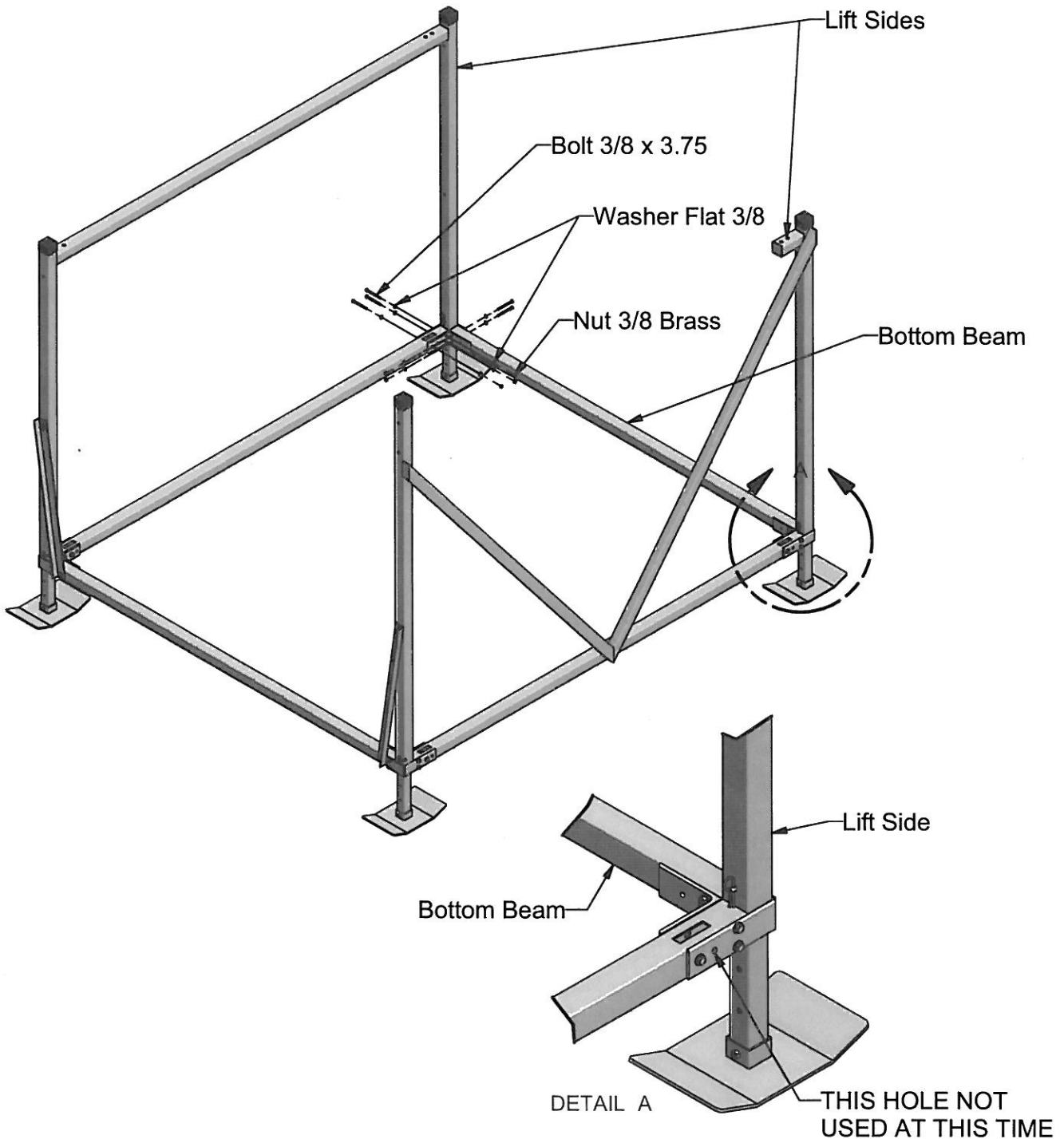

STEP 5

Set Left Rack Side in Lift V Side and Right Rack Side in Lift Opposite Side with connector angles facing out - as shown.

A - Set Aluminum Eye end of cable in the slot of the front of the lift side. Secure with one Bolt 3/8 x 3.75, two Washers Flat 3/8 and one Nut 3/8 Brass - as shown in Detail "A."

B - Insert the Eye Bolt end of cable through the hole in the top of the lift side. Secure with one Washer Flat 1/2 and one Nut 1/2 Nyloc Brass.

NOTE: Be sure washer is in place and that the nyloc nut is tightend so at least 1/4" of Eye Bolt thread is exposed.

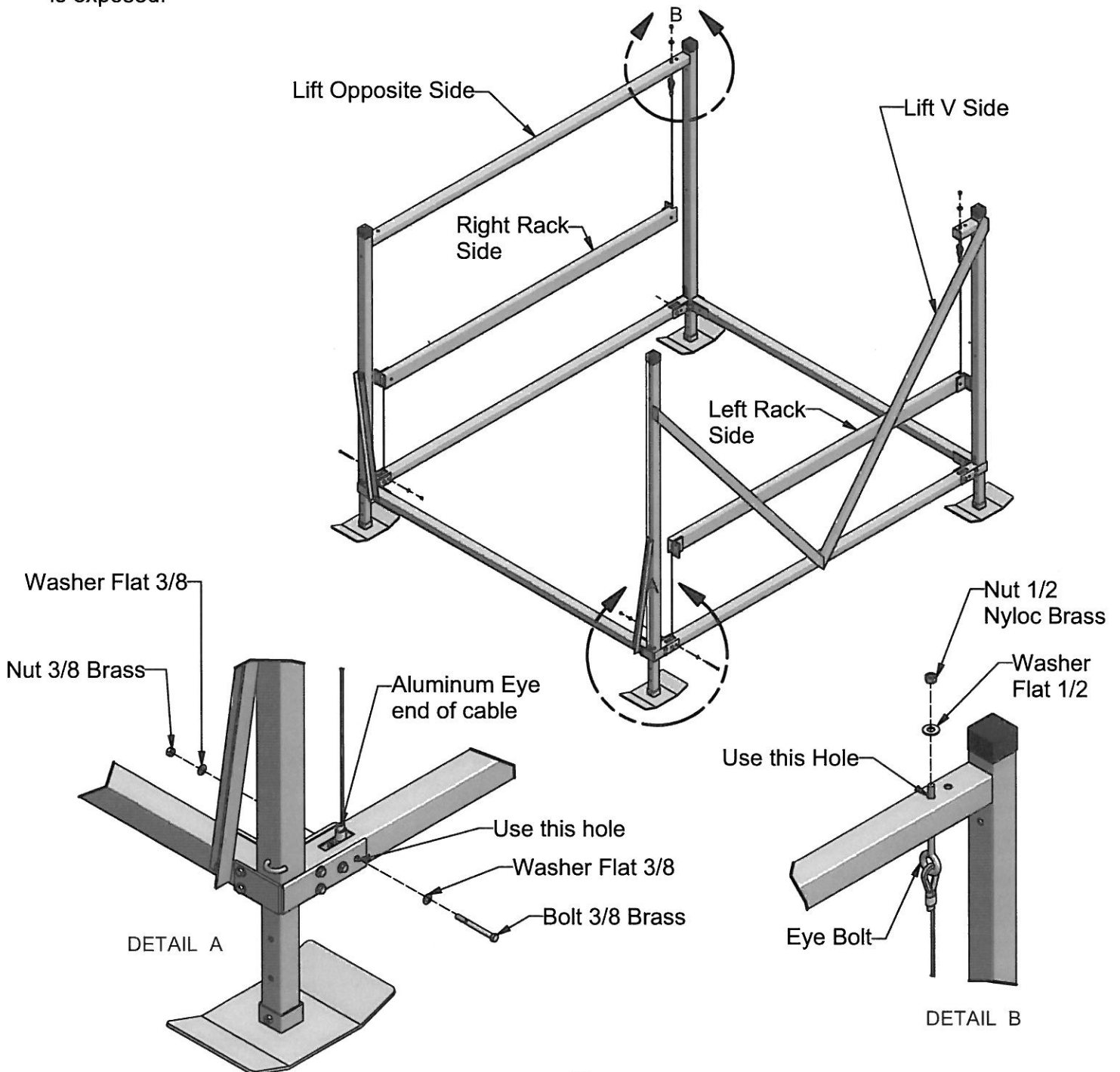

STEP 6

Attach Rear Rack to rack sides. At each end secure with one Bolt 3/8 x 1.25, two Washer Flat 3/8 and one Nut 3/8 Brass - as shown in Detail "A."

Secure Aluminum Eye end of cables to both lift sides with one Bolt 3/8 x 3.75, two Washers Flat 3/8 and one Nut 3/8 Brass - as shown in Detail "B."

Insert the Eye Bolts of the Rear Rack cables through the hole in the top of the Lift Sides. Secure with one Washer Flat 1/2 and one Nut 1/2 Nyloc Brass as shown in Detail "C."

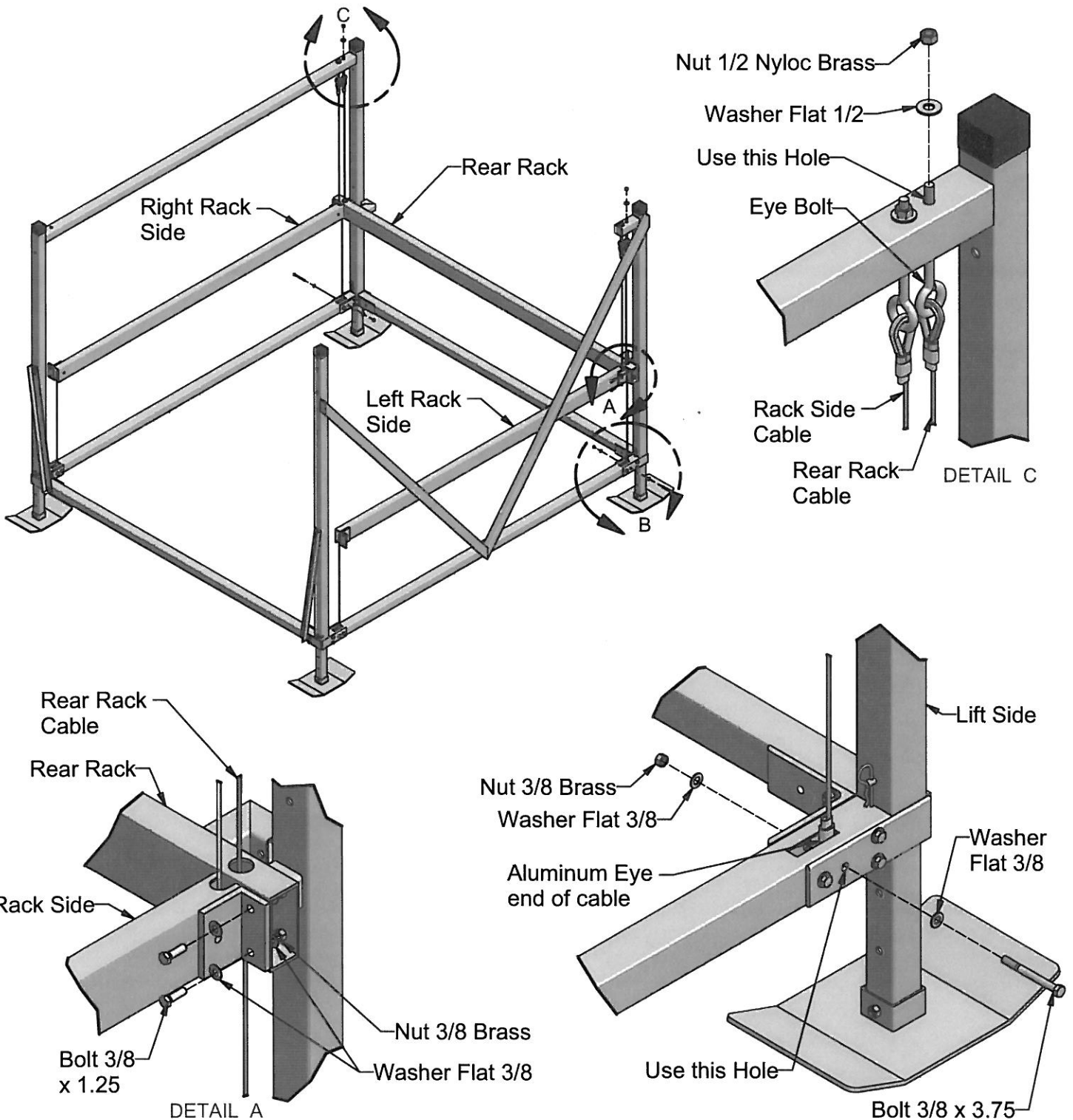

STEP 7

Set the Front Rack in place and attach to the Rack Sides. At each end secure with one Bolt 3/8 x 1.25, two Washers Flat 3/8 and one Nut 3/8 Brass in two places as shown in Detail "A."

Insert the Eye Bolt of the Front Rack cable through the hole in the top of the Lift Sides. Secure with one Washer Flat 1/2 and one Nut 1/2 Nyloc Brass as shown in Detail "B." The other end of the cable is attached to the winch as shown in Step 5 of the Winch/Wheel Instructions (page 18).

Note: There are five Eye Bolts to attach. See the drawing of Eye Bolts and cables on next page to ensure correct location.

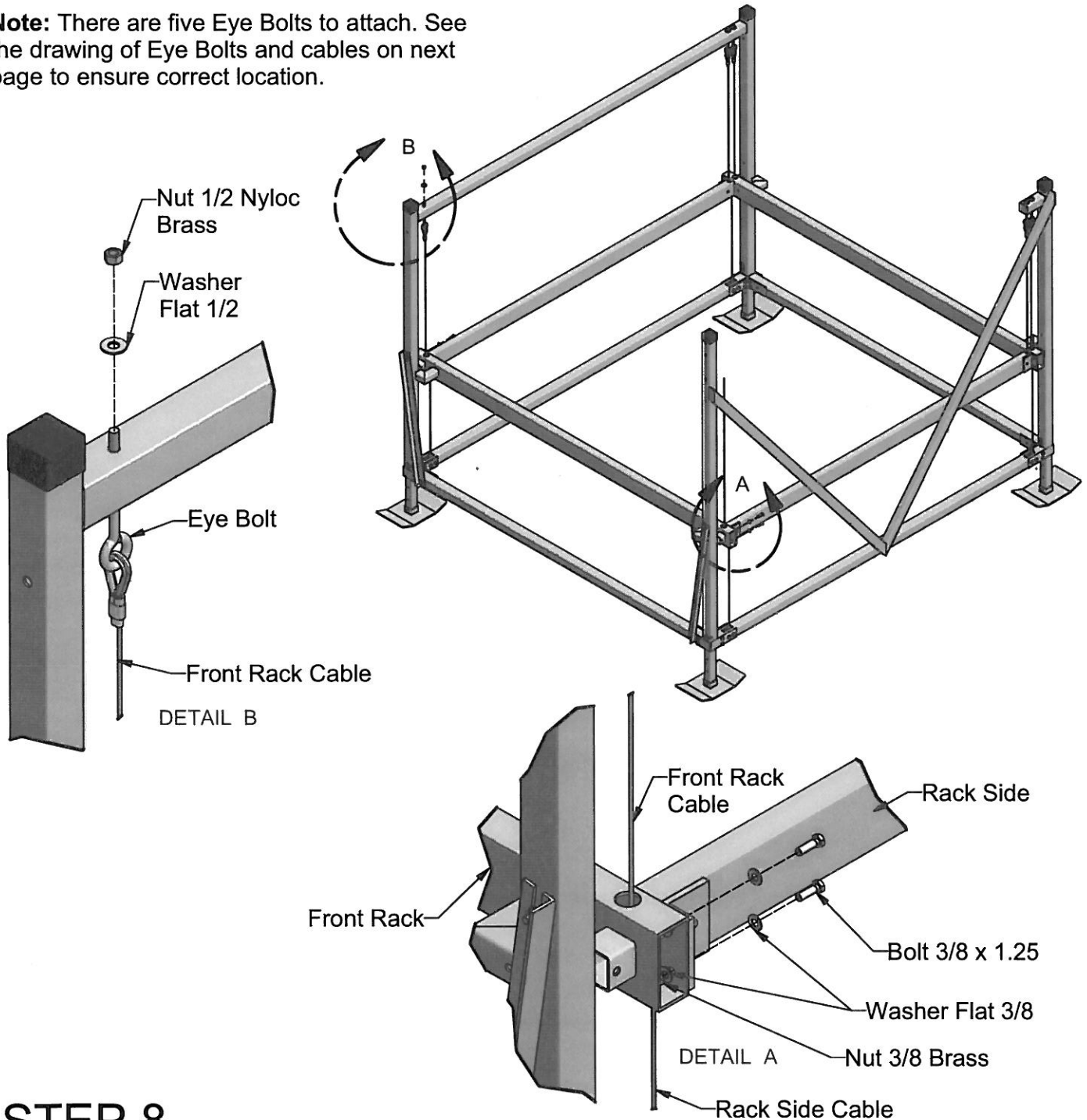

STEP 8

Firmly tighten all nuts and bolts at this time.

Note: Nyloc nuts should not be reused. If a Nyloc nut is removed it must be replaced with a new one.

Proper Cable Locations

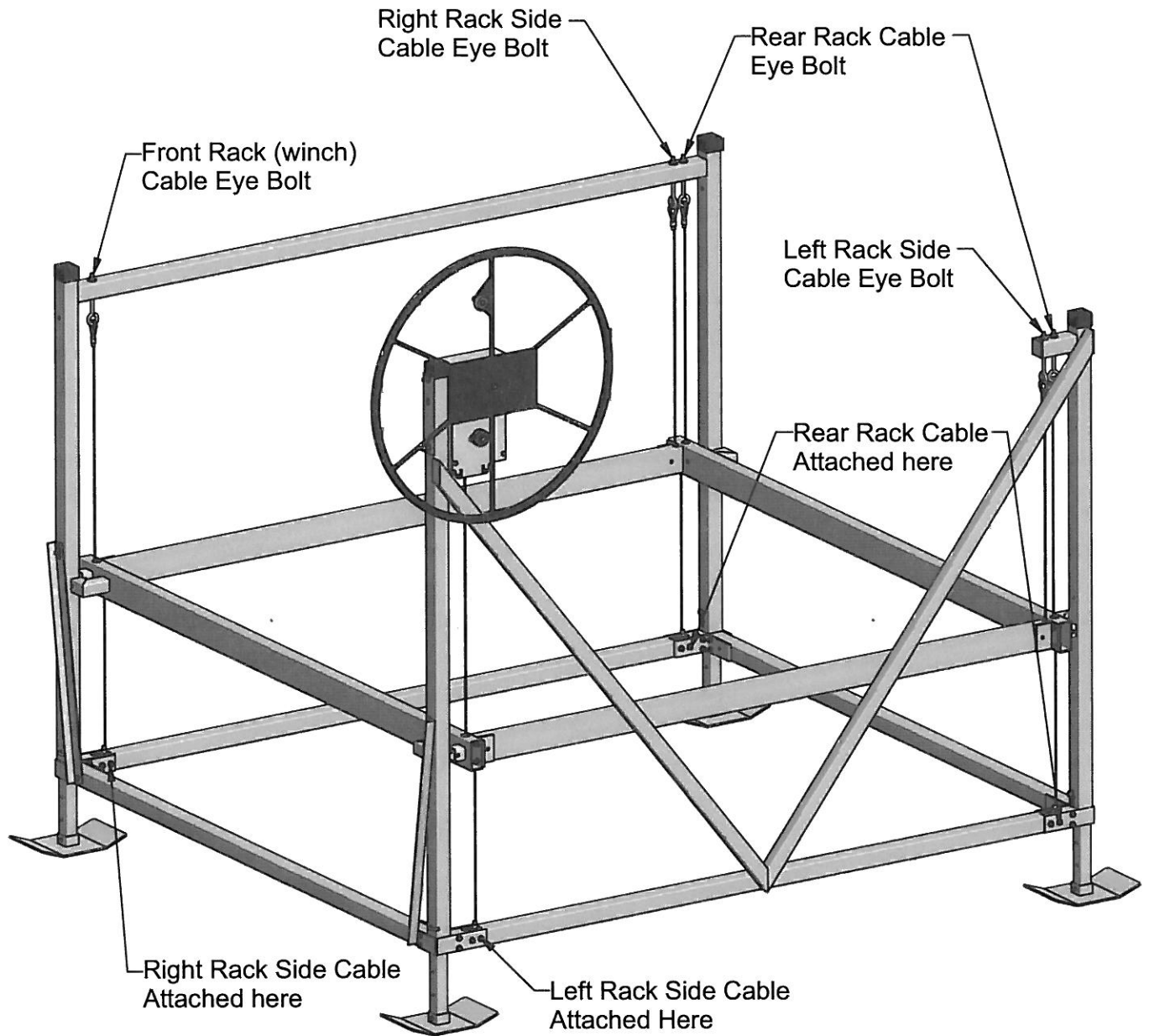

Front of Lift

CAUTION

Be sure washer is in place and that Nyloc Nut is tightened so at least 1/4" is exposed. Failure to attach cables, Eye Bolts, Washers and Nyloc Nuts correctly could result in a severe crushing, cutting or pinching injury. Severe damage to lift or boat could also occur.

WINCH / WHEEL INSTRUCTIONS

STEP 1

Remove Winch cover by unscrewing three screws.

STEP 2

Attach the Winch to the Lift V Side Upright that is twelve inches longer than the other three. Secure Winch with two Bolts 1/2 x 4, four Washers Flat 1/2, one Winch Plate and two Nuts 1/2 Brass - as shown.

Note: The bolt heads should be on the outside of the lift (the left side of the lift when facing the Lift V Side). Two Nuts 1/2 Brass and two Washers Flat 1/2 secure the Winch from the inside - as shown in Detail "A."

Note: The Wheel Shaft must be facing the outside of the lift - as shown in Detail "A."

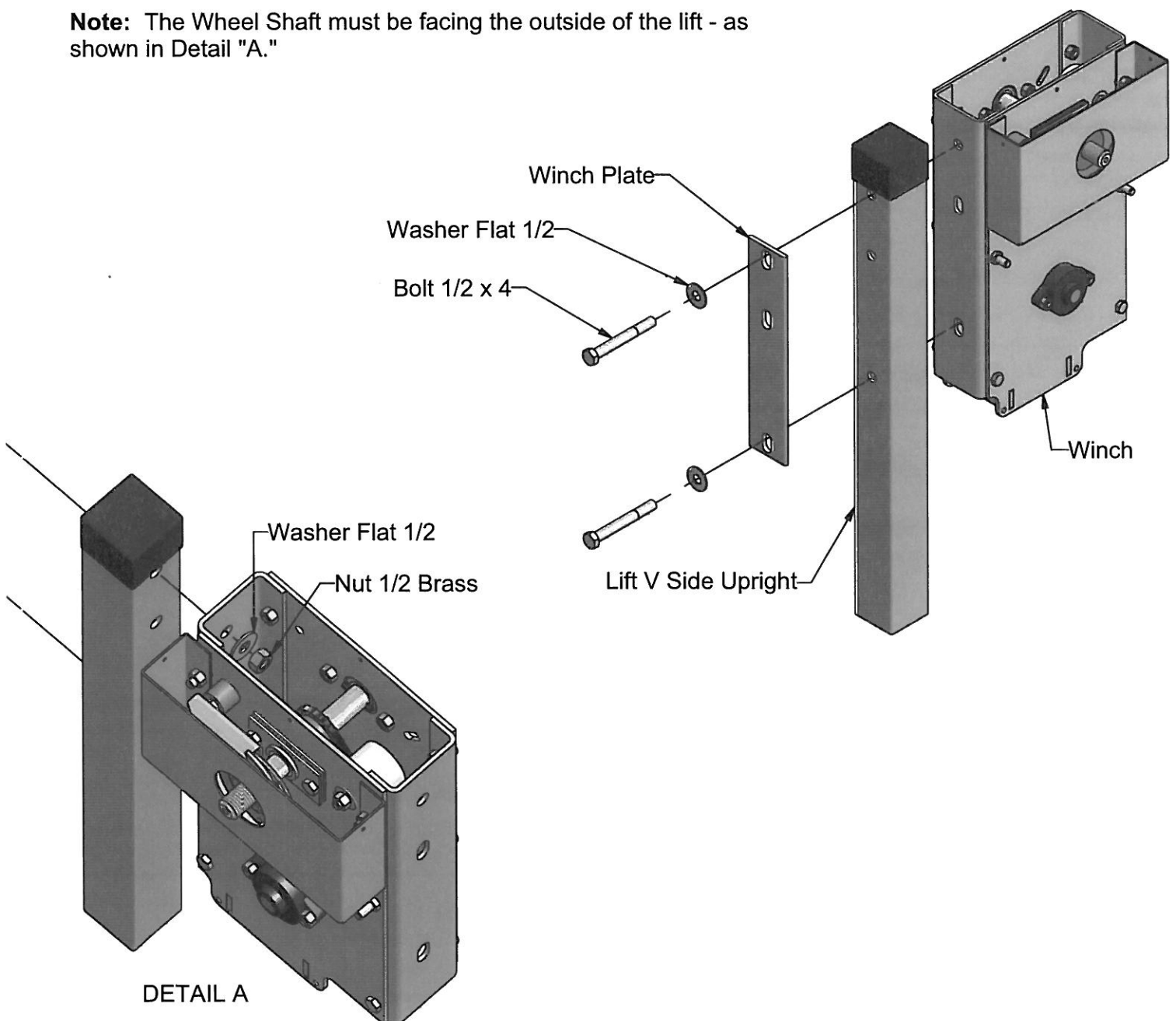

STEP 3

Slide end of cable into slotted opening on winch hub. Using a 3/16" Allen Wrench, tighten winch hub set screw to secure cable to winch hub.

NOTE: Cable must enter at slotted end of opening through hub as shown. Slide cable fully into hub opening. However do not go so far that the cable sticks out the other side of hole. This would interfere with proper cable wrapping.

NOTE: Be sure cable enters winch between the two cable guide plates (as shown).

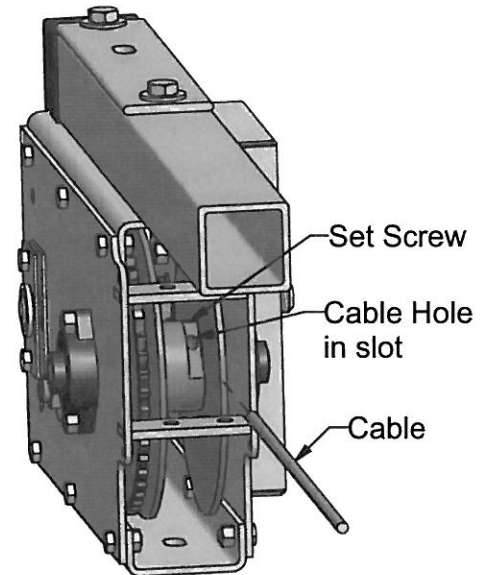
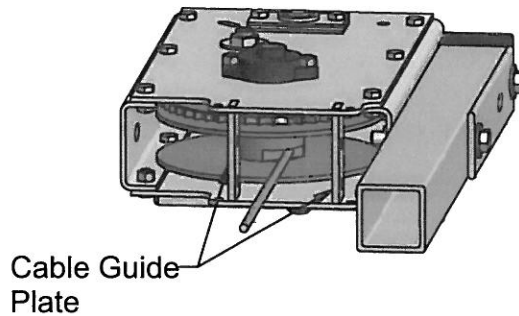

STEP 4

Hold each Cable Guide Roller in place and insert one Bolt 3/8 x 4.5 through the plates and roller, then tighten with one Nut Jam 3/8 Nyloc Brass in two places - as shown.

Insert one Bolt 1/4 x 4 through front and rear plates of winch, and secure with one Nut 1/4 Nyloc in two places as shown.

NOTE: Be sure cable is between Cable Guide Rollers.

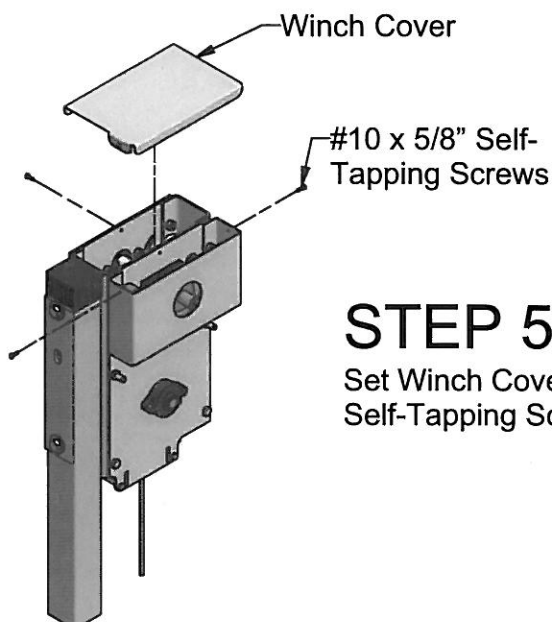
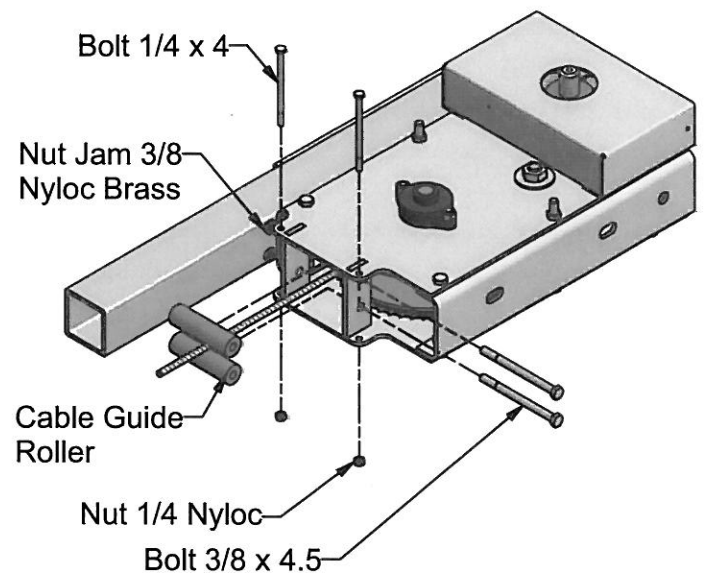

STEP 5

Set Winch Cover on Winch and secure with the three #10 x 5/8" Self-Tapping Screws that were removed in Step 1.

STEP 6

Thread Wheel clockwise on to shaft of Winch. You must thread wheel all the way on winch shaft. The wheel hub must be fully against brake pad **and** a clicking sound must be heard when turning wheel up!

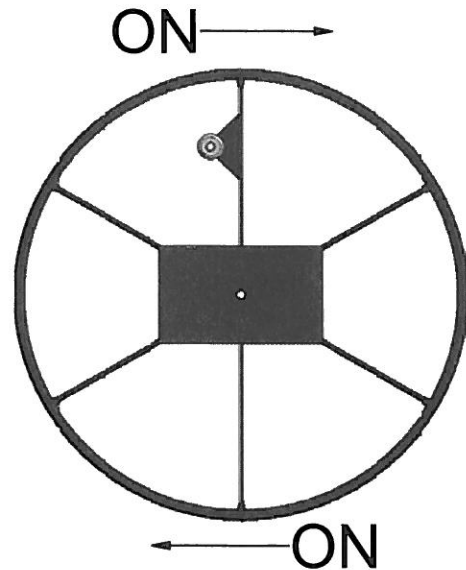

STEP 7

Using a sharp knife or razor blade, cut a small hole in the middle of the wheel, where the wheel sticker covers the attaching bolt hole.

STEP 8

Prior to securing wheel in place using the Bolt 5/16 x 1 Nyloc, stack the spacer and three Washers Flat 5/16. Then place the stack in the bolt hole in the middle of the wheel. The stack should just barely protrude out of the center bolt hole. Remove one Washer Flat 5/16 at a time until the stack just barely protrudes out of the center hole.

Once the correct number of Washers has been determined, secure the wheel in place using the Washer Flat Aluminum 1 1/8 and the Bolt 5/16 x 1 Nyloc as shown.

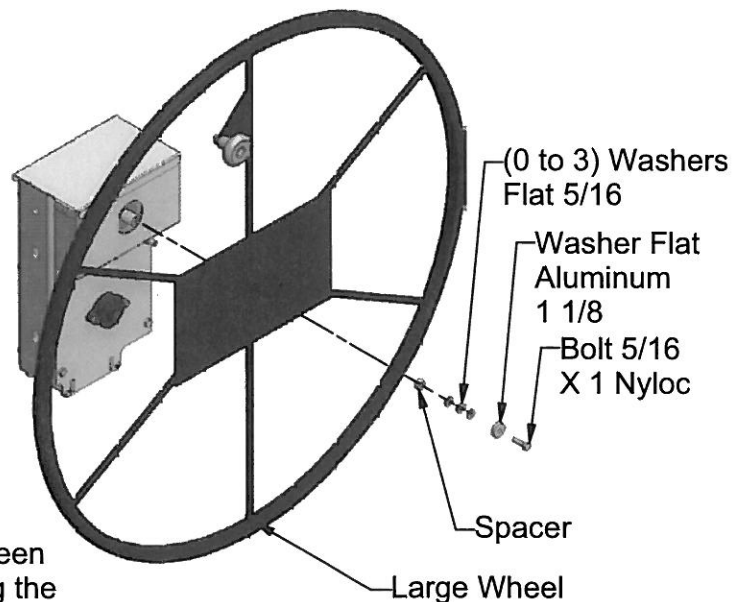

NOTE: You should be able to slide a piece of paper in the gap between sticker in the center of the wheel and the washer. The wheel should turn 1/8 to 1/4 turn prior to engaging the Washer Flat Aluminum 1 1/8.

STEP 9

Thread excess cable onto winch hub by turning wheel clockwise. Be sure cable wraps tight and uniformly on hub with each strand lying snugly next to the adjacent strand. Keep tension on the cable by holding it tight when turning the wheel to develop a proper wrap. Do not allow cable to wind up loosely on hub.

CAUTION

Use a leather glove or other hand protection to avoid cuts when applying cable pressure. Cables wrapping incorrectly will result in rapid cable wear.

Proper Cable Adjustment

a) There are four cables with Eye Bolts and nuts that must be adjusted to properly level cables. These Eye Bolts are all located near the rear uprights as shown.

b) Turn wheel so front rack beam raises about 6" above the bottom of frame. Adjust cables so all corners of rack are the same distance from frame.

Note: Adjust the cable length by turning the nut on top of the Eye Bolt. Hold the Eye Bolt stationary while adjusting the top nut. Using the frame below the rack as your reference point, measure the distance from frame to rack in each corner. These distances should all be within a 1/4 inch.

Note: Be sure washer is in place and that Nyloc Nut is tightened so at least 1/4" of Eye Bolt thread is exposed.

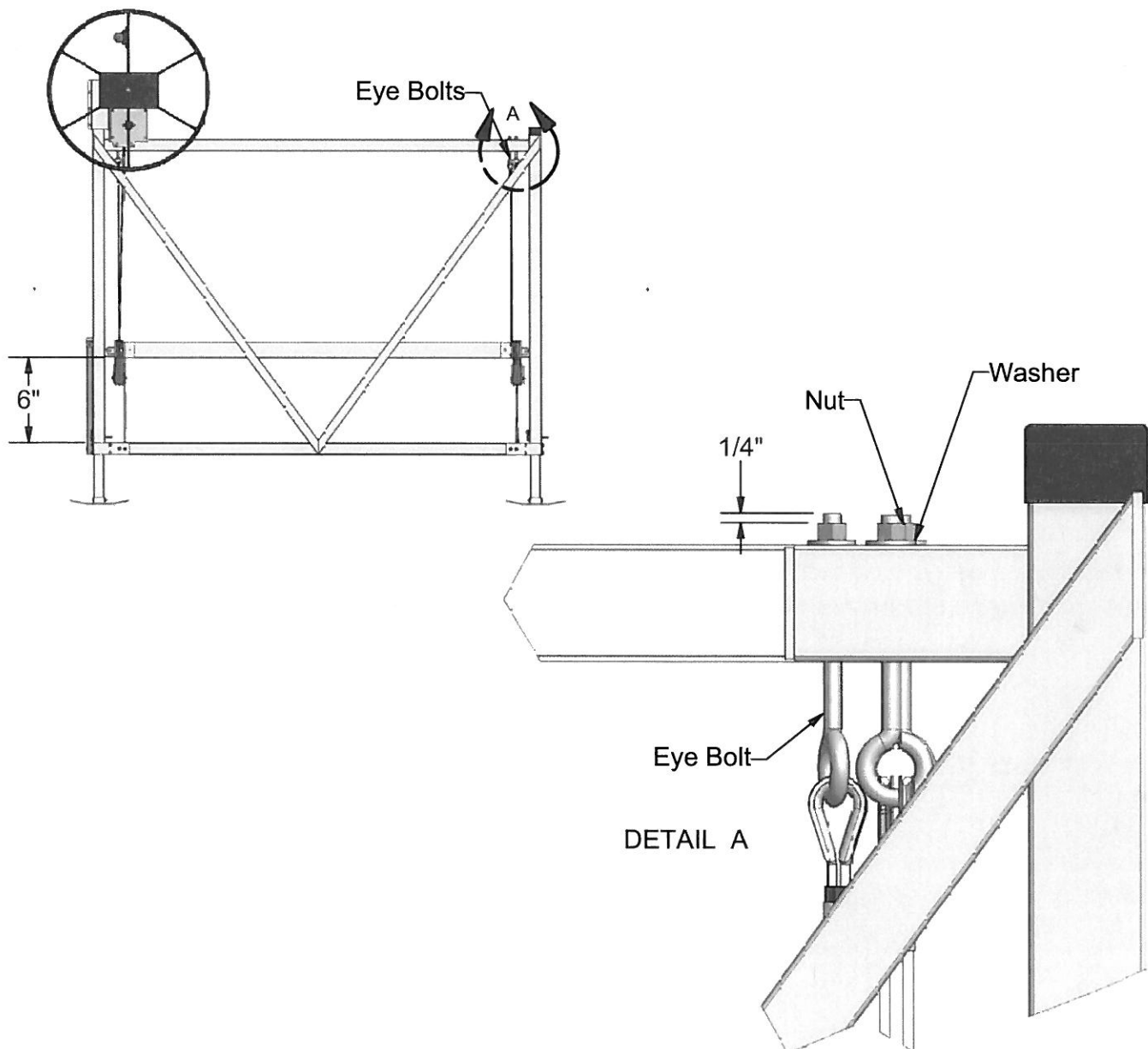

INSTALLATION INSTRUCTIONS

Do not under any circumstances, endanger yourself or risk damage to your lift or boat when installing.

- Situations will widely vary between installation sites. ShoreMaster recommends that your dealer or other trained boat lift installer train you and perform the initial installation.
- Wear protective gloves, clothing and eyewear when assembling and installing the lift.
- Do not assemble, install or use this product if items are missing or damaged.

The following are guidelines or suggestions for installation:

STEP 1

Measure the water depth of the position you want to locate the lift. Measurements should be taken at both the projected position of the end nearest shore and end furthest from shore.

STEP 2

Before installing, adjust lift legs so the boat can float into position before raising, while still allowing a high enough position so the boat can be fully raised up and out of the water.

STEP 3

Carry, lift, roll, float or slide the lift into position alongside the dock. Ask your dealer about a wheel caddy unit to allow your lift to be rolled into position.

STEP 4

Ensure that your lift is level. Measure the distance from the top of the cross beam to the water surface. The distance at each of the four corners of the lift should be within two inches of each other. If they are not, adjust the legs accordingly.

Note: If the lift legs will extend 3 feet or more, ShoreMaster recommends deep water braces to stabilize and strengthen the lift. Ask your dealer for more information.

CAUTION

The lift must be resting on the water bottom in a level, secure and stable position for safe operation. An unstable lift installation could result in tipping of the lift during operation, causing damage to watercraft and a crushing or pinching injury to the operator or bystanders.

STEP 5

After loading and operating the lift pursuant to the operating instructions, remove the boat and recheck that the lift remains level.

OPERATING INSTRUCTIONS

CAUTION

When first using the boat lift after installation, the weight of the boat may cause the lift to settle and become unbalanced. Until you are certain the lift has stabilized, make sure people are not in the immediate vicinity of the lift.

Now that you have installed and leveled the lift, you are ready to raise your boat for the first time. Prior to use, see to it that anyone who may use the lift looks upon the unit not as a toy but a piece of heavy equipment that deserves your respect and good judgment.

- Before allowing anyone to operate the lift, be sure they fully understand the proper operating procedure.
- Do not exceed maximum capacity of the lift; overloading may cause mechanical failure and serious personal injury.
- Do not allow anyone who is in the water within six feet of the lift.
- Do not allow anyone on, in or under the lift while operating.

When operating the lift, the following procedures should be adhered to:

STEP 1

Be sure the lift rack and cradles or bunks are positioned below the water surface so they will not interfere with the boat floating into position.

STEP 2

Properly balance and center the boat on the lift prior to raising. The boat should be positioned with the center of gravity near the middle of the lift. For most rear engine mounted boats, this requires you to position the boat somewhat forward in the lift.

STEP 3

Turn wheel in direction of arrow (clockwise) to raise lift. A clicking sound is heard when properly raising lift. Turning wheel and wrapping cable in wrong direction may cause fast spin down of wheel.

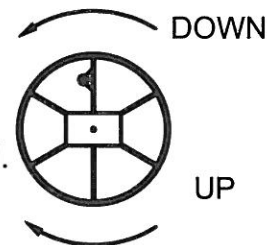

WARNING

Stay clear of lifts (facing wheel) while operating. Do not allow anyone on, in or under lift. A cable or lift part failure can cause a sudden drop of boat, resulting in a crushing or falling injury or death!

CAUTION

Do not touch wheel or attempt to stop it if fast spin down of wheel occurs. Placing hands or feet on spinning wheel can cause broken or cut limbs.

STEP 4

Carefully bring the lift up until the bunks or cradles have secured the boat. Then, stop the lift and check to see that the bunks or cradles have automatically positioned themselves to the shape of the hull, as they are designed to do. If so, continue bringing the boat out of the water until it is about one foot above the surface. Stop the lift again and check the stability of the lift, particularly to see that it is fairly level and will not topple over. Finally, continue lifting the boat while paying close attention to the positioning of the lift until it is at its desired height.

STEP 5

After loading and operating the lift, remove the boat and recheck that the lift remains level. (See Step 4 of the Installation Instructions.) If the lift is not level, the legs should be adjusted accordingly. Because the lift may settle and become unbalanced, the lift levelness should be rechecked two weeks after installation and periodically as needed.

STEP 6

If lift is without a boat in it for more than one day, raise the rack (pulleys) fully out of the water to help prevent corrosion of these parts. At all times, make sure the boat is stored high enough out of the water to avoid wave action against the hull. A moving boat as a result of wave action will damage the lift and can take the boat off the lift.

CAUTIONS:

1. Do not over raise lift rack. Stop before top of rack hits cable loops attached to Eye Bolts. Over raising could cause damage to winch, cables or other parts.
2. Do not over lower rack so slack develops in cable. Doing this could cause cable to jump off winch spool. This may result in sloppy wrapping of cable next time you raise the lift, resulting in premature wear or cable breaking. Turn wheel down one or two turns past point when craft begins to float (This must always be at some point before lift rack is contacting rear bottom beam). Then turn wheel up slightly until clicking sound is heard to secure wheel position and brake on winch.
3. Properly cover your boat, or pull your boat's plug when the boat is in a raised position. Rain water accumulating in your bilge can quickly increase your gross weight over the capacity of the lift.
4. Do not leave lift, or boat on lift, in water if ice formation is possible. Ice can severely damage your boatlift.

SAFETY MAINTENANCE

Monthly Checks

Check cables for frays, corrosion or breaks at least once a month. A cable breaking while boat is in lift could damage boat or lift. Severe bodily injury could also occur.

Spring and Fall Checks

1. Inspect nuts and bolts for damage, wear or loose connections. Tighten or replace parts as needed.
2. Inspect lift frame, pulleys, winch and pivot points for unusual wear, damage or bent parts. Replace or repair as needed.
3. Check that the rack is level with the bottom frame of your lift. Cable stretching or settling of lift could require you to adjust nuts on Eye-Bolts.
4. Lubricate winch and wheel threads. Do not get lubricant on brakepads! Brake will fail and wheel will spin down if brake pads are lubricated.
5. Check and lubricate pulleys to ensure that they are turning freely.
6. Check Eye-Bolts to make sure they are not working themselves loose.

ShoreMaster dealers usually offer service visits. Please contact them if you are unable or unwilling to perform maintenance or service to lift.

LIMITED WARRANTY

ShoreMaster, Inc. warrants all ShoreMaster brand docks and lifts purchased new by the original owner to be free from defects in the aluminum structure and welds for a period of 15 years. A five-year pro-rated warranty applies to canopy vinyls. All other components are subject to the warranty terms provided by their manufacturer.

SHOREMASTER INC WILL AT ITS OPTION REPAIR OR REPLACE WITHOUT CHARGE, OR ALLOW CREDIT FOR ANY SUCH GOODS FOUND ON EXAMINATION BY SHOREMASTER TO BE DEFECTIVE UNDER NORMAL USE AND SERVICE. THE BUYER'S REMEDIES WITH RESPECT TO DEFECTIVE GOODS SHALL BE EXCLUSIVELY LIMITED AS ABOVE PROVIDED AND IN NO EVENT SHALL THE SELLER BE LIABLE FOR INCIDENTAL OR CONSEQUENTIAL DAMAGES OF ANY NATURE. ALL REPAIR WORK MUST BE DONE BY A REGISTERED SHOREMASTER DEALER. THE WARRANTY GRANTED HEREIN IS EXPRESSLY IN LIEU OF ANY WARRANTY OF FITNESS FOR PARTICULAR PURPOSE OR WARRANTY OF MERCHANTABILITY.

This warranty does not cover damage caused by improper use, installation, overloading, accident, neglect or harmful alterations or repairs made by others, damage by snow or ice, salt water, electrolysis, severe weather conditions and Acts of God.

Written notice of a discovered defect covered under this warranty must be received by ShoreMaster, Inc., prior to the expiration of the warranty, based on the date of purchase shown on customer's invoice. Warranty on canopy frame requires proof of purchase of a ShoreMaster manufactured vinyl.

Your warranty must be registered. See the warranty card on the next page.